



Search & Rescue  
Equipment Catalogue



## Our Trusted Suppliers



**LIFESAVING  
SYSTEMS™**

A Signia Aerospace Company



*equipment limited*

*Reliable Safety - Reliable Comfort*



**Axnes**

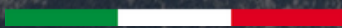

**ops-core®**



**apollo**

*Scuba*



**fourth element**

**MILITARY & PROFESSIONAL**

All Elements Protection specializes in best in breed protective, survival, rescue & communications equipment for military & civilian SAR operations.

Our extensive range includes Lifesaving Systems Corporation, Axnes Wireless Intercom Systems, Kong, Fourth Element, Apollo, Sord, Scubapro, Opscore, and many more.

## Section 1

Harnesses  
Life-vests  
Litters & Rescue Baskets  
Quick Splice  
Emergency Breathing Systems  
Strobes & Flares

## Section 2

Fins  
Boots  
Knives  
Gloves  
Waterproof Torches

## Section 3

Bags  
Helmets  
Headsets  
Wetsuits  
Drysuits

## Section 4

Axnes Wireless  
Communications Systems

## Section 5

Uniforms  
FR Garments  
Boots

[allelementsprotection.com](http://allelementsprotection.com)  
[info@allelementsprotection.com](mailto:info@allelementsprotection.com)





**LIFESAVING  
SYSTEMS™**

A Signia Aerospace Company



Lifesaving Systems has been serving the world's Search & Rescue (SAR) responders within the Aviation and Marine sectors for 40 years. Specializing in providing rescue, safety, and survival equipment not only for SAR responders, but also for industry professionals and operators working in the maritime and aviation environments. Clients include all branches of the US Military, militaries, police and fire departments, & both international and USA domestic civilian helicopter operators & rescue agencies.

# Harness & Life Vests

Available as a stand alone full body harness or with the life vest integrated, the Triton is the most flexible harness/lifevest system on the market. Designed for search and rescue, emergency service operations or anyone wanting an extremely hard wearing, low profile life-vest & harness combination, the Triton system is the ideal solution for an all round rescue harness that operates across all environments.

Designed to allow operators to enter the water, action the cylinder, deflate, inspect, repack and replace the cylinder, the Triton has the highest history of use of any life vest in rescue operations.

With a history that is hard to beat the Triton Harness Series is a tough, yet light-weight harness with the lowest profile in the water and lowest body coverage on the market thus reducing body heat mapping significantly.

Available in a range of designs and configurations to meet your operation needs.



## Triton with QLR & Life-vest

The Triton II with QLR & Lifevest, is the latest version of the Triton Rescue Harness. With MOLLE panels on the waist belt & life-vest, along with restraint strap attachment points on the hips, the Triton with QLR is the most advanced harness on the market today.

Numerous MOLLE pockets are available to allow the user to customize the needed configuration for the mission.

TSO C167, 13G & 85B certified



## Quad Lok Release

The Quad Lok Release is made from a titanium body with a stainless steel outer cover, this is the first certified system on the market that is designed for Human External Cargo operations. Dual action first stage buttons & first stage cover protect the second stage buttons, providing the release under load capability the industry has been searching for. Designed so that a customer can buy a sizing set of harnesses and multiple use QLR's to reduce costs.

TSO C167 certified with the Triton harness.



## Triton Harness

The stand alone Triton Harness is available in both the traditional direct connection design with the Tallon equipment hook, or available as the base to the Triton with QLR.

Designed for companies that do not need a life vest or want to operate the system with the Triton PAX or Osprey lifevest systems for over-water operations. TSO C167 Certified



## Triton Survivor

The TRITON Survivor is based on the TRITON Harness, just modified for use on survivors. The same (TSO Approved) harness that keeps you safe, now keeps them safe during a rescue. A red back cover delineates a clear inside and outside to the harness that allows it to go on like a jacket. There are 5,000 lb rated handles on the back for securing and transferring the survivors from the hoist and into the airframe, and retro and other materials added for visibility.

Unlike AVED devices – which weigh more and cost more – Survivors ride upright in this device which reduces the effects of rotor wash and makes the ride more comfortable for everyone. With two hoisting positions, from the waist or chest, you have options to use the device for the recovery of survivors, or the delivery of personnel to the scene depending on their level of training. TSO C167, 13G & 85B certified



## Triton PAX

It is doubtful that any inflatable bladder design has seen as much in-water action as the LSC TRITON. The flotation vest provides 35 lbs of buoyancy via manually inflated CO2. The folding pattern and snap closure create a comfortable low-profile fitting around the neck. A MOLE PALS System allows for the attachment of pockets for storage of auxiliary survival equipment. Supplied with LRS Strobe, TSO 13G and 85B Certified



## Osprey Life-vest

The Low Profile Flotation Collar is just 6mm over the collar bone, eliminating interference with helmets common with other collars. The harness system is arguably the most comfortable and has the lowest profile of any vest type design on the market reducing body surface area contact and heat mapping. Lightweight with a 2 yearly service schedule. the Osprey system is TSO 13G & 85B certified.



## Osprey Harness

The Osprey MOLLE Vest & Harness incorporates all the features of the #745-M with the addition of an integrated lifting harness and stow-able rear tether attachment. Intended for aircrew or tactical personnel who may require deployment or recovery by helicopter hoist. Currently undergoing certification under both TSO C167 & 13G.





## Triton II Molle with Life-vest

The Triton II with Molle Rescue Harness, is a modern rescue harness made with Molle panels on the hips and life-vest. TSO C167, 13G & 85B certified making this one of the most versatile harnesses on the market. Quick release buckles and full corrosion free hardware are standard on all LSC harnesses, making them a long lasting harness that has been in use with the US Coast Guard for over 25 years.



## Quad Lok Belt

A simple restraint belt that has been updated to gain certification to ATSO C1001. Features a 5" wide inner belt with two outer Mil-Spec nylon webbing waist belts. Each waist belt is secured with double locking buckles, providing the extra level of safety needed in the aviation environment. The quick-adjusting, single tether strap located in the center back of the belt has a stainless steel safety hook, available in standard and large sizes.



## Quick Splice Kit

The wedge style Quick Splice is designed for in flight replacement of the hoist hook should the cable become damaged, broken or entangled. Allowing crew members to cut the cable and secure a replacement hook to continue with the mission. A thumbscrew pre-loads the wedge against the cable. As the load increases, the internal forces securing the cable get tighter and tighter for a positive cable grip. The Quick Splice is available separately or as an Emergency Hook Replacement Kit with attached D-LOK hook, cable cutters and case.



# Rescue Strops

## 214 Quick Strop

Constructed of MIL-SPEC webbing and stainless steel hardware. Designed to be placed under the arms and around the back. Rescue personnel can slide the Strop over the head of the survivor and into place in a single quick motion. The friction buckle is slid down the strop and attached to an adjustable safety strap. Approved by CASA under ATSO-C1003.  
NSN 4240-01-545-6722.



## Quick Strop SAP

214-SAP Quick Strop provides more support in the seat and has a sling with straps that distribute weight more evenly for more comfort and less compression of the chest than the conventional strop. It also utilizes a single V-Ring for attachment to the hoist hook. A secondary safety hook is installed near the hook attachment V-Ring. This design allows the Quick Strop to be used without an over the head technique for applications or opening the winch hook.



## 214 Hypo Strap

Designed to be used in conjunction with our #214 (series) Quick Strops to provide support under a victim's legs to effect a more horizontal recovery position. Some rescue units use a double-strop system in cases of suspected mild hypothermia, at only 340 grams, this device easily stows in your kit bag until needed, and is out of the way when it isn't. For use directly on the hoist hook or attached to a carabiner and onto the hook. Not designed as a recovery strop, only to be used to support the legs.



# MEDEVAC I LITTERS

The Medevac I litter is engineered to withstand the conditions encountered in remote operations, such as in-water rescue, submarine/shipboard rescue, mountain rescue, and other restricted areas requiring a versatile, narrow, and low-profile litter.

The integrated flotation is designed to self-right and float with the patient's head slightly reclined to provide maximum freeboard. Includes a stowage case with backpack harness for easy transport & two carrying harnesses to allow personnel free use of their hands while carrying litter and patient.

Tubular stainless steel or lightweight titanium frame & skid construction. Fast action, sliding couplers secure the two halves of the litter and are locked in place within seconds. The Medevac litter may be hoisted in either vertical or horizontal positions for manoeuvring within vessels and only horizontally to aircraft.

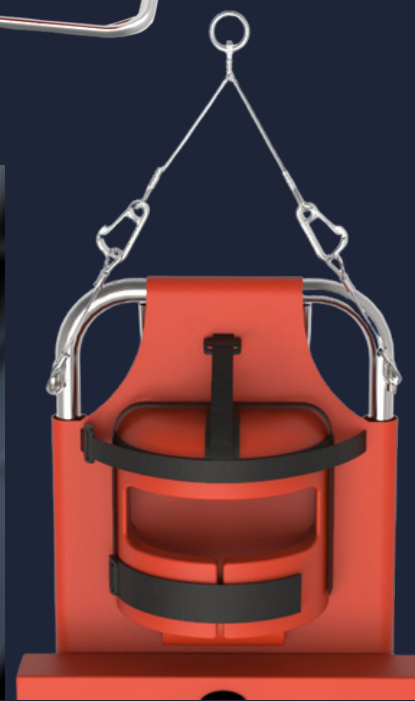
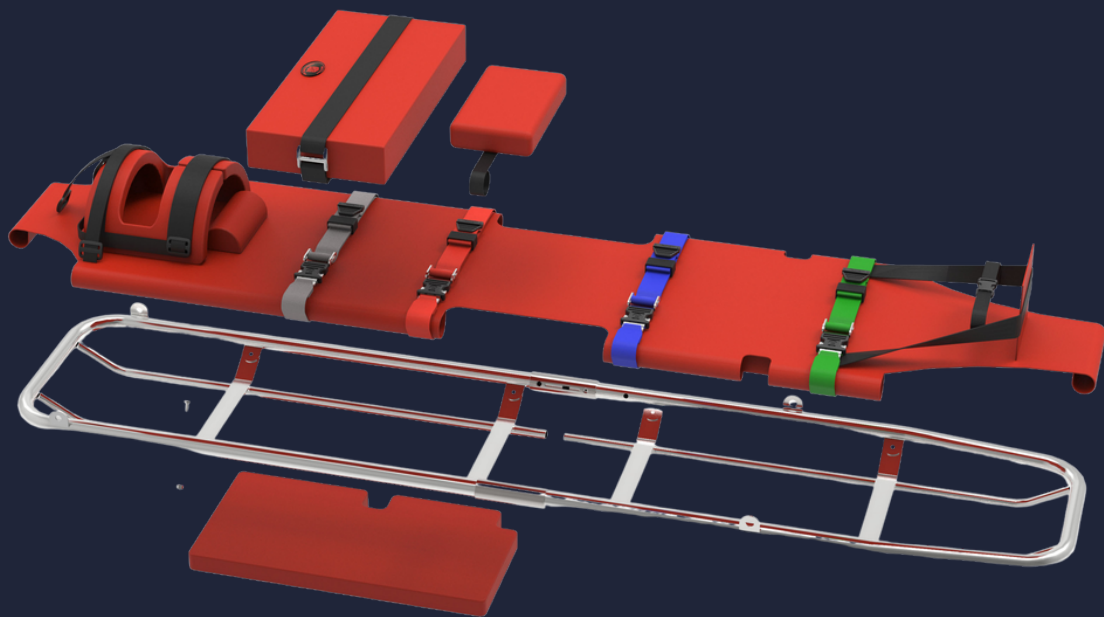

# MEDEVAC II LITTERS

The Medevac II is a modern Stokes-type litter constructed for long life in the marine environment and is available in two models; a rigid frame (404 series) or break-apart frame (406 series).

The 406 series is secured via screw-couplers with self-aligning pins to secure the top tubes firmly together. This coupler system is the strongest in use on any stretcher today. When assembled, the Medevac IIA Break-Apart is as robust as the rigid Medevac II. Both the Medevac II & IIA litters are offered with polished Type 304 Stainless Steel and lightweight Titanium frames.

Float kits are designed over water operations with the newly designed face shield providing head protection from undercarriage and skids during entry to the cabin, this also provides an increased level of comfort for the casualty during extrication by reducing the down wash on the face.

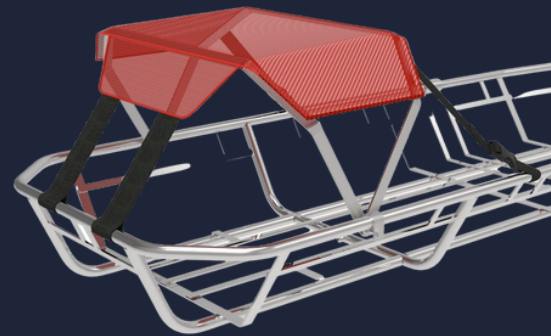

# Rescue Baskets

The US Coast Guard estimate that 85% of all hoist rescues are carried out by the basket, with a simple and robust design and history of use that can not be beaten the rescue basket is the safest way to extricate a person to the helicopter.

All components are non-corrosive and require minimal maintenance for extended service life. Inherent flotation provides positive self-righting and reserve buoyancy. Float covers are printed with safety pictorials and have high-intensity retroreflective markings.

The 495L has a lowered lifting eye and the 499 is a rigid design, at AEP we recommend the 495 standard, as this has the most clearance for entry and compact design for in cabin storage. The 495L was made for the modern Huey airframe and the internal hoist.

Dimensions: 115cm Long, 65cm Wide, 25cm High when stowed, 105cm High when assembled, Weight 17.5kg.

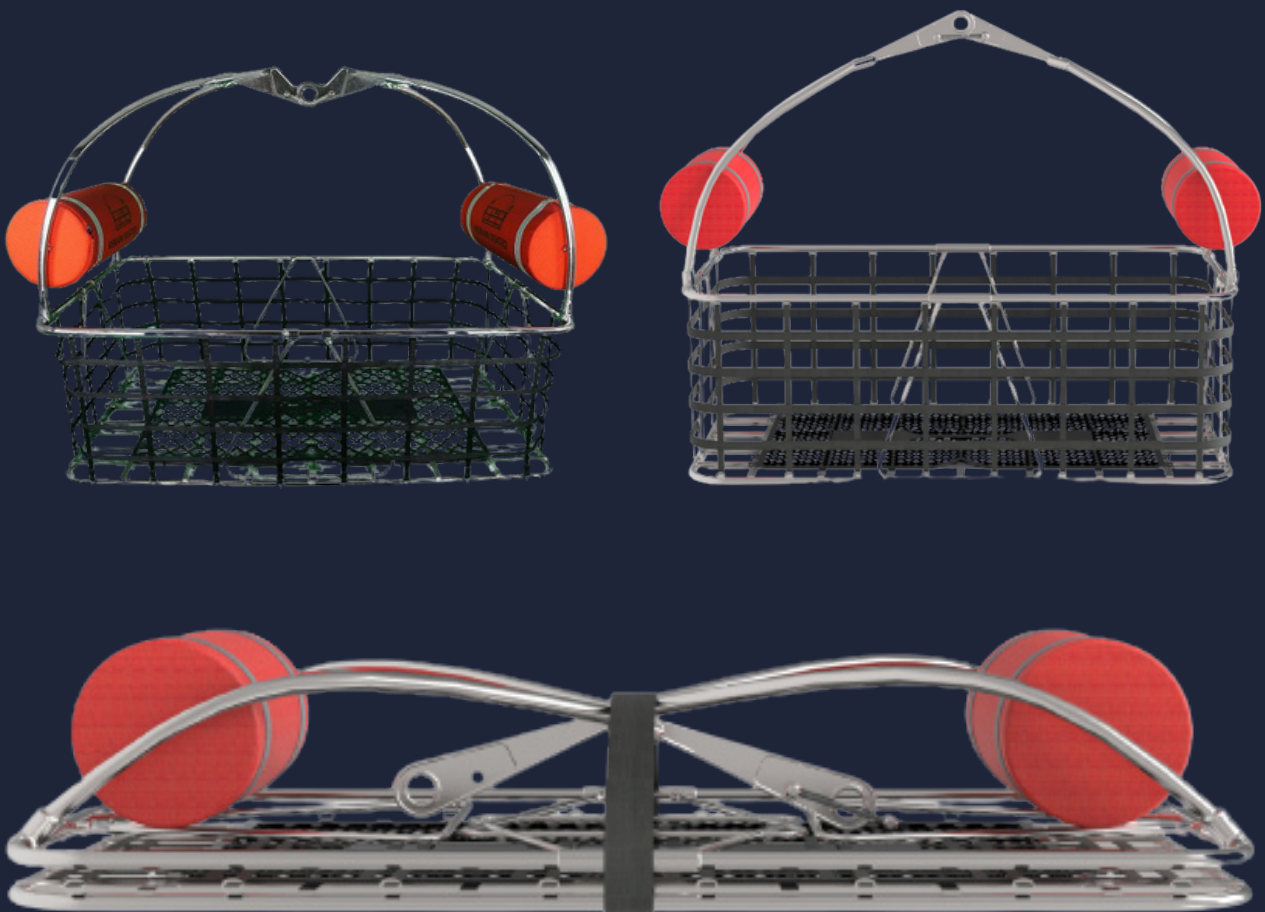



Kong designs and manufactures equipment specifically for the purposes of sport, technical climbing, caving, canyoning, industrial, rescue and tactical military/police operations. Kong's core business is safety and rescue, originating in the 1830's, Kong has been at the forefront of mountaineering techniques, manufacturing of climbing and rescue equipment for almost 200 years.



## Target Pro Turbo

Rescue harness, rope access and positioning, situations where light weight and freedom of movement are primary characteristics. All buckles are made of stainless steel AISI 316 to ensure maximum resistance in corrosive environments.

Wide, breathable and padded leg loops for maximum comfort of use. Ergonomic waist belt with light structure for the best fit and comfort. Yellow fluoro finishing for the best visibility during operational phase.

EN 12277/C, EN 361, EN 358, EN 12277/A, EN 813, UIAA



## Everest Kit Bag

Rescue helicopter bag designed to be used either with a spine board and/or with vacuum mattress.

Modular design allows for increased flexibility, supplied in a hoist-able and backpack-able bag.

Manufactured with tear-proof nylon and Cordura®  
Weight: kg 4





Kong have a range of anti-rotation devices to suit many operational styles, needs & purposes





## Kong Res-Cot

Two handles for connection to the helicopter hoist hook with different attachment points, identified by a color code, to determine the correct positioning angle.

Internal cradle with fireproof padding covered with breathable, removable and washable mesh.

Transparent upper pocket for positioning and carriage of medical apparatus, external slot for connecting any anti-rotation system.





## Kong X-One & X-Two

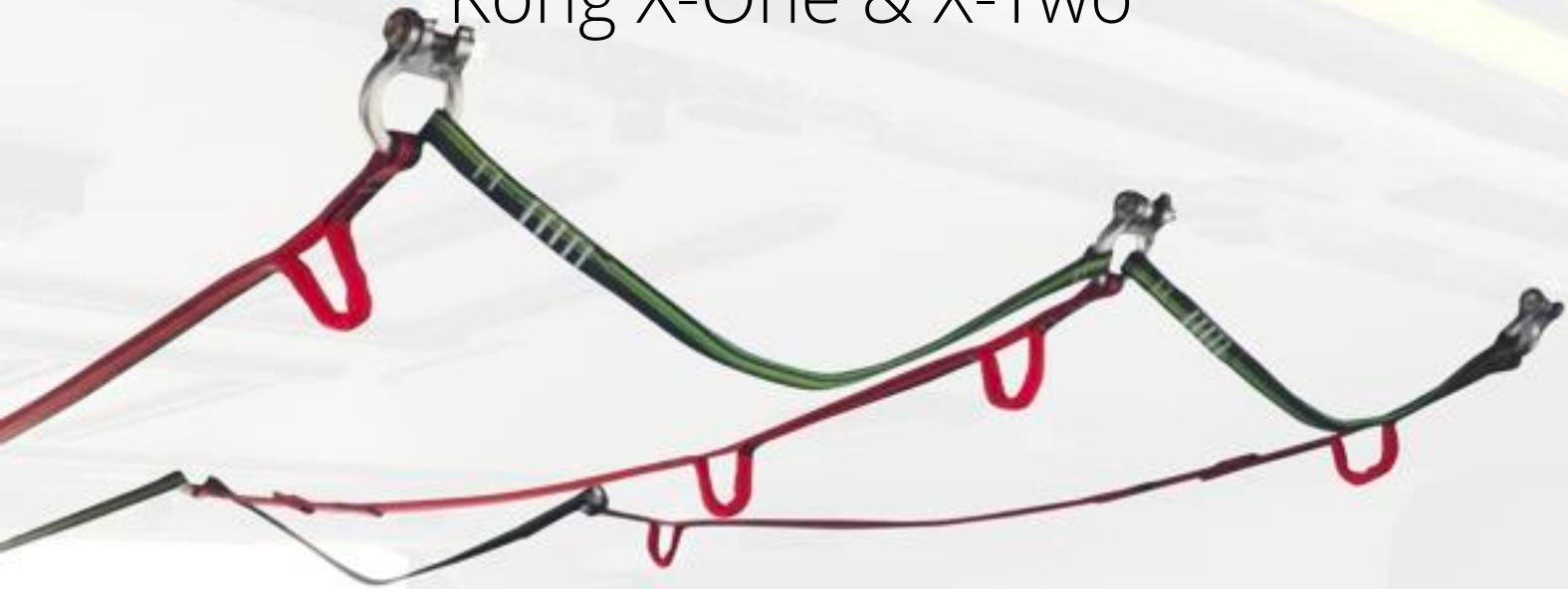

Overhead cargo points for the AW139 & AW169 airframes, provided with flight manual supplements.



# Emergency Breathing Systems

The original Helicopter Underwater Escape Device, the HEED 3 systems are robust, reliable and simple. With remote charging systems available, including hand pump options, the HEED3 is the ideal system for remote operations. An annual dip inspection is carried out by the operator and a 5 yearly offsite breakdown service make the HEED3 is the obvious choice in Emergency Breathing Systems.



## HEED 3 - 175 Series

Simple rugged design utilises the same time proven technology found in typical regulators used by SCUBA Divers around the world. The always-on, breathe on demand, balanced single stage regulator is easy to use, maintain and service. Weighting just 700grams, with 1.7cu ft providing approx 32 breaths on the surface with a breathing rate of 1.5L/min.



## HEED 3 - 200 Series

Designed with a hose and second stage the HEED 200 Series has an on off valve, high quality braided hose in either 20 or 27 inch lengths, the balanced downstream second stage, is easy to use, maintain and service. Weighting 900 grams, with 2.0cu ft providing approx 38 breaths on the surface with a breathing rate of 1.5L/min.



## HEED 3 Refilling Options

### Scuba Tank Refill Yoke

Attach to a dive cylinder to decant and equalise pressures across cylinders or fits to a diving compressor



HEED 3 hand pump is a bicycle style pump that can tolerate pressures up to 3000 psi. Dry-Pac HEED desiccant only to be used with hand pump.

High Pressure Portable Air Compressor is an electrically powered unit, simple operation and auto shutoff design. The portable compressor provides an alternative to decanting from regular dive cylinders or hand pumping.



## Apollo Emergency Breathing System

Simple Emergency Breathing System, made from high quality diving components slight larger in physical size than HEED 3 systems. Able to be serviced at any Apollo approved diving shop.

Length of cylinder/first stage: 270mm

Weight when full of air: 1.6kg

Cylinder volume: 0.22 litres, 207 Bar

Cylinder diameter: 50mm

Air supply: Approximately 30 breaths at the surface, based on 1.5L per minute.

Apollo yoke adaptor for filling.



# Signaling Equipment

## Rescue Me 406MHz PLB

The smallest and lightest Personal Locator Beacon (PLB) on the market, waterproof to 15m, with an operational life of over 24 hours, a 7 year battery life and 7 year warranty. The Ocean Signal PLB features 66 channel GPS receiver that operates on the global Cospas Sarsat system that does not require any ongoing subscriptions.

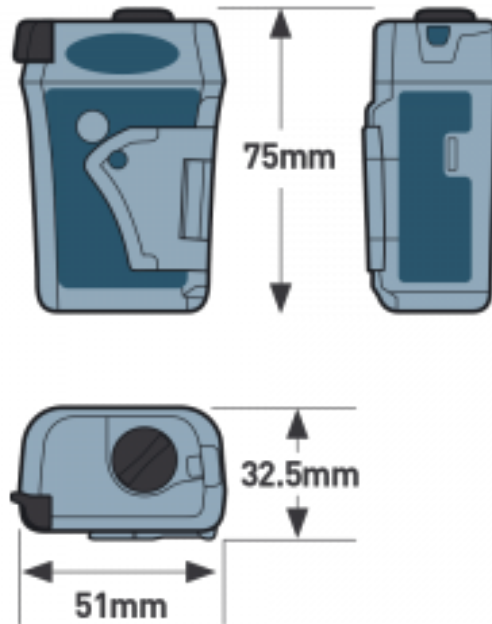

## Ocean Signal EDF1

The RescueME EDF1 electronic distress flare offers users a safe and long-lasting solution to visual signalling in an emergency. The light output is a beam of over 30° throughout the full 360° azimuth. Light is also distributed throughout the hemisphere above the unit to ensure visibility from the air.

Unlike single use pyrotechnic flares the RescueME EDF1 can be used repeatedly in any of its four modes, ensuring continued visibility is maintained over a longer period. The unit is both safe to store and operate while also eliminating any worries associated with disposal.

The compact size and rugged design means the rescueME EDF1 is the perfect safety product for a grab bag, life raft or hiker's backpack.



## Ocean Signal M100 & M100X

The M100 and M100X MSLD (Maritime Survivor Locating Device) from Ocean Signal has been designed to meet the needs of the professional marine market and its offshore workers. Once activated the M100 and M100X will transmit an alert to all AIS receivers and AIS enabled plotters in the vicinity. The M100 and M100X also transmit a 121.5 MHz homing signal in addition to the AIS. The integrated 66 channel GPS ensures a position update is provided every minute via AIS. The M100X is designed to meet the European ATEX directive and IECEx approval for use in zone 2 explosive atmospheres.



## LSC Long Range Strobes - 640 & 641

641 LRS - TSO 85B Can be set for water activation

640 LRS is designed for manual activation only

With 60 flashes a minute for over 18 Hours the

LSC range of strobes are highly effective and simple to use.

7-Degree Spot Reflector for Long Range Signaling

AA Alkaline or Lithium Battery

10-Minute (LRS) Auto Revert Back to Signal Strobe

Tether Cord to Secure Light in Equipment Pocket

High Visibility Orange Case

U.S. Coast Guard Approval: 161.112/109/0



## LSC Tri-Sirius Strobe - 643

Developed for SAR personnel, the Tri-Sirius features a

multi-position switch giving the user three operating

modes:

- **Flashing White Strobe:** The standard white emergency signal common to all Sirius Strobes.
- **Flashing Blue Strobe:** Differentiates the swimmer from other marker lights in the area.
- **Green Work Lamp:** Provides broad green hue is of low intensity to reduce adverse effects on the operator's night vision.



## LSC Mil Tac Strobe - 642

A military/tactical personal strobe light offers the user

the choice of a flashing covert IR signal or visible

flashing bright white signal. The default IR mode

prevents inadvertent white flash during critical covert

operations. The user must cycle the main switch

three (3) times within five (5) seconds to activate the

white signal light, with IR LED's that emit IR wavelength

only there is no no chance of white light leakage.







# Section 2

## Essential Rescue Swimmer PPE



# Fins

## Bio Fin Ranger Pro

The Bio Fin Ranger is designed to be partnered with almost any military or emergency services boot on the market, due to the larger foot pocket and spring retention strap. The overall size the Bio Fin Ranger Pro is short and with a soft compound rubber construction is highly suited to the rescue swimmer role. Must be worn with boots due to the size of the foot pocket.



## Bio Fin Pro

The Bio Fin Pro is a longer version of the Bio Fin Ranger, with a smaller foot pocket allowing traditional dive booties.

The Bio Fin Pro is a popular fin used by rescue swimmers due to its high propulsion and flexible design providing very low fatigue for power output, highly recommended. The only disadvantage is that the longer blades are a little cumbersome when in the cabin.



## Da Fins

The Da Fins are a shorter, high propulsion fin, used by ocean lifeguards and highly suited to turbulent waters. The short blade design results in high propulsion, these are our recommended fins for surf zone rescues. The only disadvantage is that foot protection can not be worn with the Dafin range due to the snug fit design. If you can sneak two sets of fins into your kit bag, the Da Fins are the ideal partner to a larger ocean fin.



## Da Fin - Fin Savers

Simple wrap around design, fin savers are highly recommended for all water rescue roles.

Should your fin slip off it is simply retained around the ankle and prevents a lost fin becoming an issue during a rescue.



## Slipstream Monoprene Fin by OMS

An original military style fin made from strong rubber producing a powerful fin that requires continual training due to the weight and blade strength. High quality used by military swimmers the world over.

Available with spring or rubber straps.

Suitable to be worn with the ATB Pro Boots.



## SAR Shredder Fin

The U.S. Divers SAR Shredder Fin are a short but stiff fin made from rubber boot with a hard polymer blade. The fin pocket fits water rescue and dive booties, features include:

- Securing ankle strap
- Quick release buckles
- Short blade ideal for moving around in confined areas
- Stiff blade that requires continual use in training environments and the pool to avoid ankle fatigue.



# Rescue Swimmer Boots

## Altama Maritime Assault Boot

Similar in design to the original Converse Chuck Taylors, made from high abrasion quick drying 1000D Cordura, with a high quality rubber sole providing high grip when wet.

Designed to be worn with socks which makes the Altama Maritime Assault Boot ideal for tropical environments.



## Rock Hopper Booties

Fourth Element Rock Hopper are a simple bootie with a high quality sole for operators who do not need bigger boots or are in hotter climates.

- Simple foot pocket style bootie
- Heel reinforcement
- 3mm stretch neoprene and rubber construction



## Amphibian Boots

The 5mm neoprene and rubber boot with a solid underfoot and toe cap ideal for cold environments or where swimmers want additional underfoot protection

- Ergonomic foot bed
- Heel and arch support
- Underfoot cushioning
- Heavy duty side zip
- Fin strap retainer



## ATB Pro Lace Up Boot

The ATB Pro is a 3mm soft super stretch neoprene lace up boot that is ideal for intermediate and cold waters with the advantage of the full lace system.

Instep drain mesh allowing water to escape, not suited to hot climates

- Tactical Rubber lugged jungle type sole
- Reinforced high-abrasion resistant toe and heel



## NRS 5mm Lace up Boot

Ideal for Cold waters the NRS boots are made from a 5 mm neoprene sock with lace up synthetic upper. Reinforced heel lug for retention of fins, with a heavy duty sole providing good grip on varied terrain.

Our warmest and toughest water boot in the range, the NRS boot will keep your feet warm in cold water.



# Dive Masks

## Apollo SV2 Dive Mask

Simple yet high quality dive mask with rubber strap, these are our highest selling dive mask. Silicone face seal with Tempered Glass Comfortable and fit over the Gath Helmets easily.



## Sea Vision 2000

High quality dive mask, issued to US Coast Guard Rescue Swimmers. Strong rubber strap with cyalume stick retention loop above eyes.



## Scubapro Mask & Odin Straps

The Odin strap system is the only system on the market to be paired with the Opscore helmets, making these a full water solution for the rescue swimmer role. The Odin Straps feature adjustable elastic straps that integrate with the Opscore rails. Our most professional solution when combined with the Opscore FAST Bump, AMP waterproof headset and PNG helicopter/maritime, wireless intercom system.



# Snorkles

## Dry Flex Snorkel

Featuring a comfortable silicone mouth piece and easy purge system, the dry flex snorkel is tough to beat and our best selling snorkel.



## Fourth Element Float Snorkel

Featuring a positively buoyant ridge and soft silicone mouth-piece and body, the float snorkel is the best on the market for those swimmers wanting a simple, indestructible snorkel that does not have a purge valve.



# Gloves

## Riggers Gloves

A high visibility glove with leather palm that is highly suited to the down the wire role, with touch screen index fingers and thumbs.



Providing good dexterity and comfortable fit, the Ringers Gloves are highly suited to both over land and in water operations.

## LSC Winch Operator and Line Handling Gloves

LSC Winch Operator & Line handling Gloves

Designed to be worn as an over glove with open finger tips and reinforced palms.

The hoist operators glove has an extra reinforcement for hoist operators a simple and effective over glove, available in a left or right single glove

Line handling gloves come as a pair and has more dexterity due to only 2 layers of leather.





# Knives

## SQR Knife

- Point or blunt tip
- Available in never rust titanium or 420 stainless steel
- Mini design that can be attached to the harness or life vest
- Available with retention strap to ensure security of knife



## LSC Titanium Rescue Knife

Our most popular knife due to the simple design and never rust titanium blade. Featuring a blunt tip, fixed blade with a line cutter & serrated edge.

Available with a Molle Pouch



## Hook Knife with Molle Pouch

A simple low profile stainless steel hook knife with a molle pouch

Designed to fit to any Molle vest and is pres stud secured for easy access when needed.

Available in black or Multicam (shown)



# Section 3

## Bags, Helmets, Wetsuits, Drysuits



# Bags & Packs

## ARGO Backpack & Duffel Bag

The Argo Backpack and Duffel Bags are made from 420D Waterproof PVC with welded seams providing waterproof construction and simple roll down and clip securing making these a waterproof design. The most popular in our range due to price and simplicity for rescue swimmer kit bags the Argo bags won't let you down.



## Duffel Bags

Available in 60, 90 & 120 liter size, the Fourth Element duffel bags are made from heavy-duty PVC, with high quality clasps and buckles. Featuring double-lined, hard-wearing base and padded rucksack carry straps with internal mesh pocket in lid. These traditional style duffel bags are the most suitable in our range for securing larger bulky items or lots of kit in an easy to move bag that will last a long time.



AEP can supply the full range of Fourth Elements products, if there is something in the range you like, please don't hesitate to reach out.



## Hydration Helmet Carrier

Ideal small pack for rescue operations and as a down the wire personal kit bag. The expandable pocket holds a tactical or climbing helmet with insertable back protector and camelbak options, this is a small bag that delivers a large advantage in a rescue operation.



Light weight 500D Cordura construction with an internal hydration bladder sleeve, small admin pouch with Velcro closure inside and covered in Molle allowing customisation and security of extra small kit items. The minimalistic approach for a streamline design is fastly becoming a replacement for a traditional helmet bag for all flight crews.



## Strike pack

Originally designed for 24 to 48 hour military operations the Strike pack is highly flexible and suitable for the SAR environment. 2 x internal mesh pockets & a removable internal Molle panel providing ultimate flexibility & user options.



Featuring a hoistable attachment point and openings for Hydration Packs, the Strike Pack is ideal for overnight kit bags or even containing medical equipment in a compact manner.

Both the Hydration helmet Carrier and Strike Kit Bag are available in a range of colours and bespoke design options.





# Fourth Element Dry Suits

At AEP we work closely with dry suit manufactures designing and supplying bespoke and off the shelf suits for search and rescue & military operations.

With a highly flexible design approach we ensure that the customers receive dry suits that are going to operate in the environment encountered.

Material range from Trilaminate to Nomex Goretex and FR base design, in both high visibility and covert designs with the ability to configure Molle, pockets and reflective striping according to the customers needs.

Having supplied dry suits to many customers globally AEP have the knowledge and experience to meet your needs.



# Wetsuits

All Elements Protection works closely with local manufactures to produce a bespoke range of wetsuits to meet the needs of the rescue swimmer. We have the ability to supply a range from 2mm to 5mm in one and two piece design.

For tropical environments we recommend a two piece design made from 2mm Neoprene pants & Lycra top, with a 2mm Neoprene vest and 2mm Neoprene long sleeve top.

For operations in cold waters such as southern Australia and New Zealand we recommend a 5mm one piece design with additional thermal vests & hoods. This concept allows swimmers to layer depending on the environmental conditions of the day and operating area. With experience supplying wetsuits from northern Australia to Southern Tasmania and even through to the Faroe Islands off Norway, AEP are able to design a solution to meet the operational conditions expected.

Features include:

- Protection around seat, knees and elbows
- Various material thickness and styles
- Open and closed cell Neoprene & lycra
- Front zip for thermal regulation when in aircraft for long periods of time
- Highly visible contrasting colours
- One or two piece design, two piece allows crews to partially dress to manage heat fatigue on long searches



# Headsets

## Axnes Pelitor Headset System

The Axnes Pelitor CH5 Headset offers the highest noise attenuation available in a simple headset. With a Carbon level microphone providing very quality and clarity this is a simple solution that can be worn as a headset or attached to rail mounts for either the Team Wendy or Opscore range of tactical style helmets, or able to be used with climbing helmets.



## Opscore AMP Headset

The Opscore AMP headset range offers best in class for waterproof headset solutions on the market. When connected to the Axnes MP50 system the AMP provides full ICS to the rescue swimmer in the water and in the aircraft. Available as a stand alone headset or fitted to an Opscore helmet via the rail mount system. Available in Black, Tan or Camouflage.





# Helmets

## Gath - Petzel - Kong

AEP stock a wide range of water rescue and climbing style helmets to meet customers specific needs. From the Gath brand for simple water operations through to Petzl and Kong varieties for remote area applications. Available with and without eye and ear protection to meet operational needs.



## Opscore Range

Opscore have a range of lightweight tactical style helmets available highly suited to the rescue and emergency services role. The FAST Bump is EN 1385 certified with the Carbon variations being designed for environments where high impact and blunt force trauma risk mitigation is needed. Shown in tactical camoflage, the range includes, black, tan & red colours. Opscore have a wide range of accessories to match their helmets.





# Axnes

PNG Mission Wireless Intercom Systems

Axnes PNG Wireless Intercom Systems, keeping the rescue swimmer in the communications loop throughout the mission, from engine start to engine stop with fully waterproof headset options.



The Axens PNG is a highly adaptable full mission wireless intercom system designed for small team operations no matter what the role, platform or mission.



### Advanced Features

NVG Class B  
GPS tracking with FLIR & Trakka  
integration capabilities  
AIS SART Tx capabilities



### Group Intercom Technology

Group & intercom loops with  
simultaneous multiple group  
attendance on a single frequency



### Clear Communication

Full duplex, adaptive noise cancelling,  
echo cancelling & non-interrupted  
VOX with repeater hub technology  
that allows for transmission on  
installed role radios



### Operational Modes

Intercom, Direct & Local Modes  
Connects to all major wired intercom  
systems  
Provides robust connection & range  
both inside and outside the platform



## PNG MP50 & MP30 Handsets

Providing the full duplex, digitally secure, robust UHF link to the base station



The MP50 is designed for maritime operations with SAR, CSAR and Special Operations in mind. The wireless handheld transceiver is submersible down to 3m/9ft of seawater. The MP50 operates a dual band marine VHF radio & AIS SART transmission. The MP50 is the best choice for water or amphibious operations.



The MP30 is designed for land & platform-based scenarios. Targeted applications include EMS, law enforcement, cargo & armored vehicles. Unlike the MP50, the MP30 is not designed to be submersible in seawater, but thanks to its full rugged metal housing it can be used even in heavy rain, snow & mud. The MP30 can be installed with a Bluetooth module, providing connection to tablet or smartphone.



## PNG Base Stations

Providing full situational awareness throughout the mission



The CP50 aviation approved control panel enables control of the channels, set up, GPS data display & other features.

The CP50 is connected to the BST50 base station via a dedicated CAN bus.



The BST50 aviation approved base station is connected to an intercom box at a headset or user position. It acts as the interface between the existing intercom system & wireless crew handsets.



The BST30 & BST35 are mobile versions of the PNG base station, which can be operated as a standalone base or connected to an existing intercom system. The BST30 is powered via 11 to 33VDC connection. The BST35 contains a lithium ion 10 hour internal battery.



The BST60 vehicle base allows a mounted or dismounted team to have clear, robust & effective wireless communications whilst inside & outside the vehicle. The BST60 is able to integrate to existing systems or operate as a stand alone system.

## The Wireless Advantage

The PNG provides constant, continual communication between team members via a digitally secure UHF link. The base station directly integrates to onboard internal communications systems via a headset or user position, this integration allows the wireless handsets to receive all communications both internally & externally of the platform.

## Robust Trusted Design

Developed & produced in Norway, Axnes specializes in supplying advanced, highly durable, wireless intercom systems that are actively deployed in demanding & harsh environments on various platforms such as aircraft, ground vehicles & vessels globally. With over 2000 operationally deployed systems, Axnes are trusted as approved suppliers to several leading aviation OEM's, including Airbus, Leonardo, Sikorsky & Bell Textron in both rotary & fixed wing platforms.



## Intelligent Headset Integration

The PNG handsets are designed to allow customer to utilise existing headsets, typically wired for US Nato aviation pinouts, the handsets automatically range across dynamic, electric, high impedance & low impedance headsets. Configurations & adaptations are easily achieved through connection leads or simple configuration changes.

## Polyconnect System Installation

The Polyconnect software system allows users to manage integration with any hardwired intercom system, providing a wireless expansion to a limitless number of handsets. Future proof development allows integration across a range of platforms via CAN Bus interface & a highly adaptable design philosophy.

## Aviation Certified - Digitally Secure

Axnes holds EASA Part 21-G & Part 145 approvals along with AS9100 & ISO 9001 certifications. Our products are AES 256 secure with advanced military encryption options for our police & military customers.







Platform mounted, 20G rated, DC power chargers accept a wide voltage supply range, from 10 to 33VDC that can be mounted in several configuration settings, available for both MP50 and MP30 handsets

Desk-top chargers accept universal power supply from 100 to 250VAC, 50 or 60Hz, and power cords for any national standard

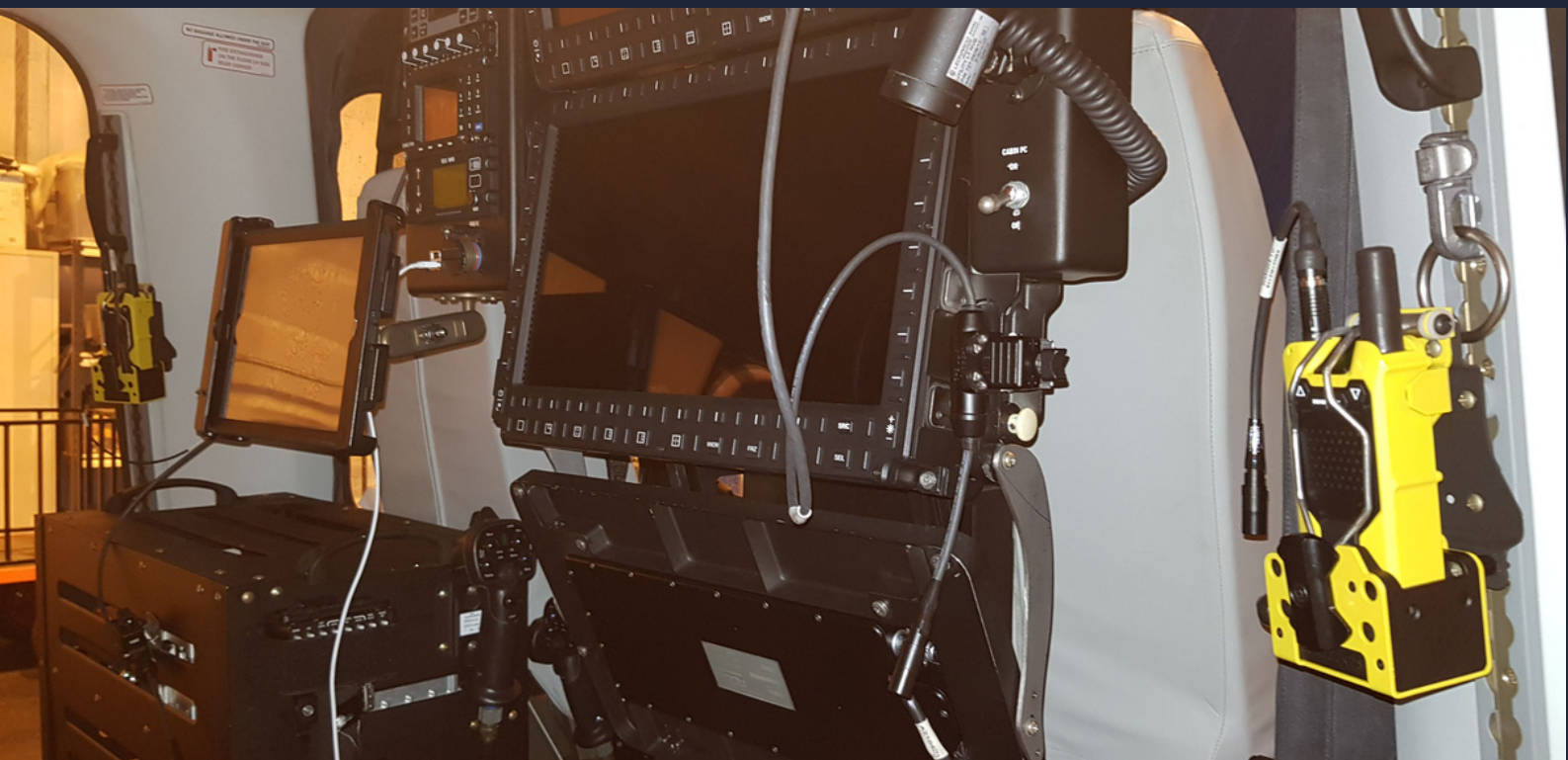



## Over 25 years of Wireless Intercom Operations

Founded & headquartered in Norway Axnes have been producing best in breed wireless intercom systems for global customers to the highly demanding standards required of the helicopter search & rescue industry for over 25 years.

With significant numbers of operationally deployed systems, Axnes have been trusted to provide the world leaders of search & rescue operations with reliable, robust, crystal clear communications in the worlds most challenging environments & demanding roles.

System References include:

Airbus

Bell Textron

Leonardo

Sikorsky

Multiple Nato military assets

Global footprint for both helicopter and fixed wing operations

The Axnes PNG is the full mission wireless intercom system trusted globally for over 25 years.







**equipment limited**  
*Reliable Safety - Reliable Comfort*

# Specialist Flight Suit Range



Rig Equipment have been delivering mission critical garments for over 15 years



***equipment limited***

***Reliable Safety - Reliable Comfort***

Rig Equipment is a family business, based in the United Kingdom have been delivering specialist FR garments to EN & ISO standards for over 15 years.

Driven by a passion to progress and develop solutions for emergency services, Rig Equipment is a leader in innovation and design. Traditional uniforms have been re-invented to address the growing demands and the challenges faced by the emergency units they support and supply.

All garments are manufactured by highly experienced personnel at the company's manufacturing base in the UK. All specialist materials and components are sourced from the United Kingdom, Germany, France, Belgium and Spain.

AEP supply Rig Equipment to the Australian and New Zealand markets in both custom and off the shelf designs.

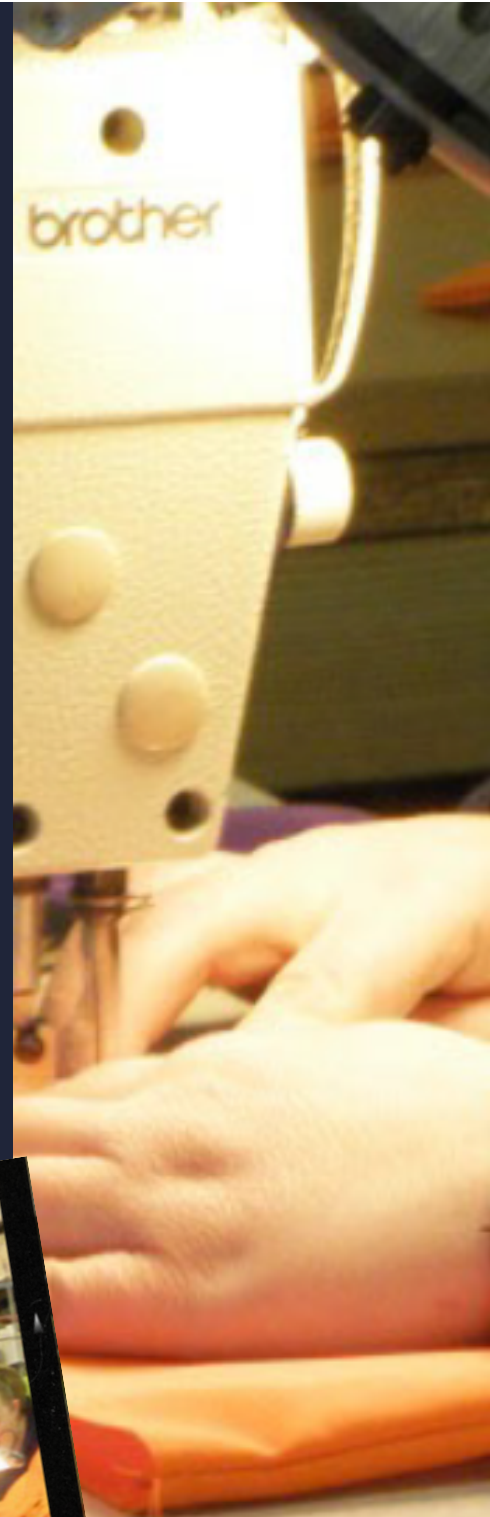



# Standards

Rig Equipment produce garments to a wide range of standards depending upon user applications and customers operational requirements.

Some of our common standards include:

EN ISO 11611

EN ISO 11612

EN ISO 15025

EN ISO 1149

EN ISO 15797



# GB Dynamic Range

The GB Dynamic pants are tailored for operational SAR and Medical crews moving around the cabin with features such as;

- Raised rear waist line with stretch panel
- Crye or standard foam insert kneepad options
- Dual zip thigh pockets with lay flat baffles
- Velcro closures on the lower leg pockets with lay flay baffles

Designed to be paired with either the GB Dynamic Shirt or FS2 Corporate Top.

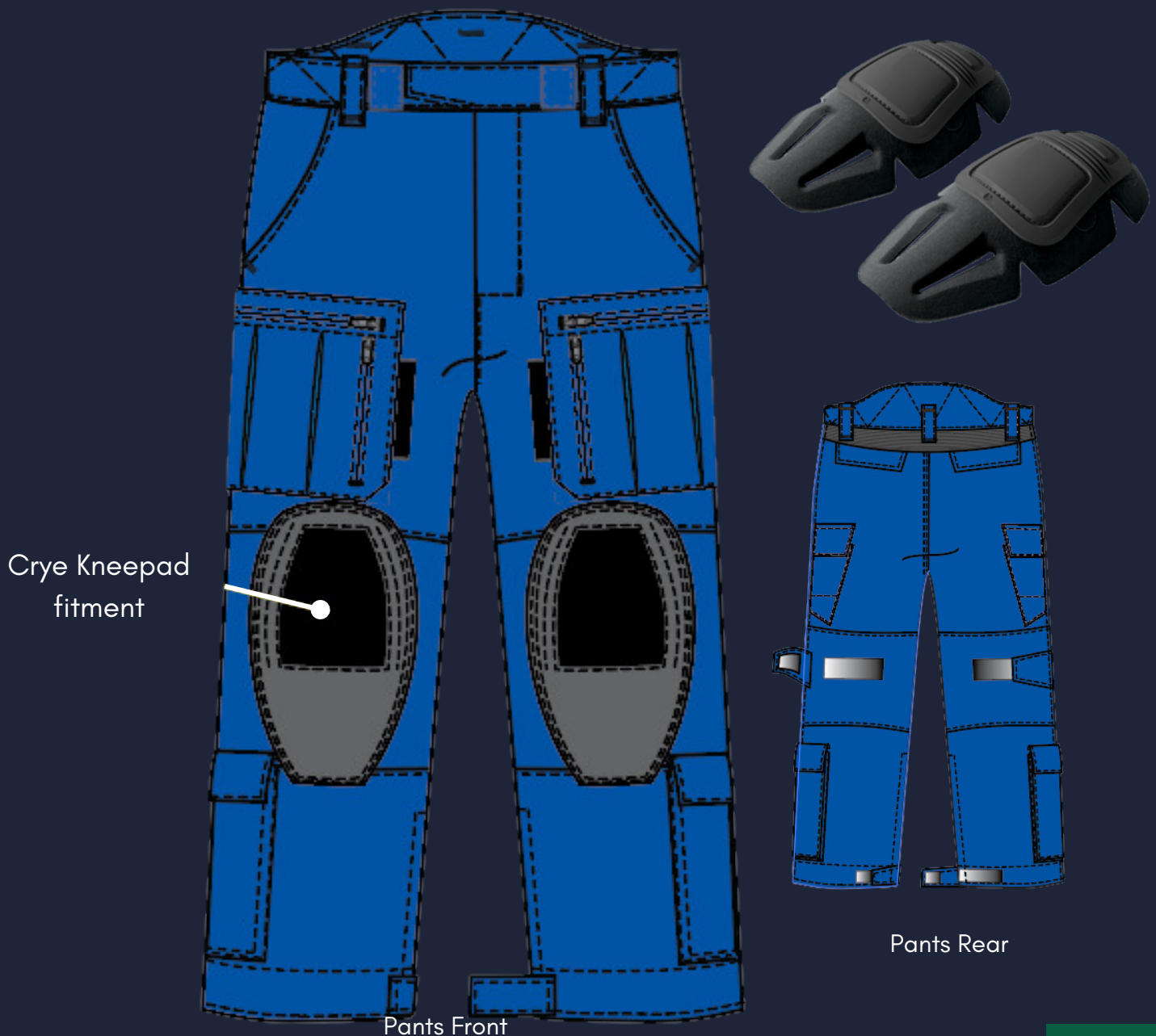



# GB Dynamic Shirt

The GB Dynamic Shirt consists of Nomex sleeves and collar, with comfortable T-Shirt material core to provide layering options.

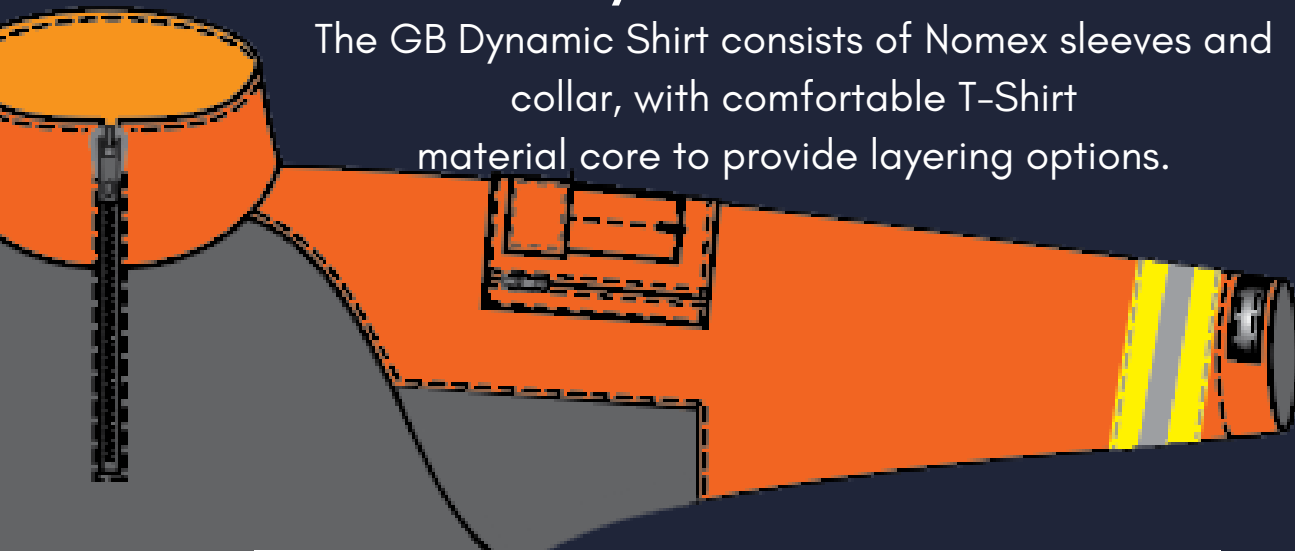

Simple Collar and Raglan Sleeves allow for easy fit when combined with the lightweight torso material. Developed on the back of military and policing applications, these tops are becoming increasingly popular in any role requiring heat mitigation, a layering approach and increased comfort.

# Dynamic Design Options

Available in a range of colours, Red, Orange, Green, Navy, Black  
(and more) to meet operational needs.



Velcro & zip closure at waist for increased comfort and flexibility



Lay flat baffled pocket with check list scribble pad & pen pockets

Lay flat baffled pocket on thigh

High wear knee pads with removable padding and Crye Knee pad options

Lower leg inside seam zips

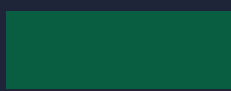



Stretch paneling with raised rear waist designed to hold on the waist when bending and moving on-scene



Removable braces with belt loops



Shear pocket with kevlar reinforcement



Velcro tabs behind the knees for comfort

Baffled lower leg pockets with closure to prevent kneeling on zips

Our bespoke design philosophy is to work with customers to understand the roles performed, equipment carried, environmental conditions faced, visibility considerations. This ensures we supply a professional, comfortable and practical uniform, that will enable crews to undertake the roles as safely as possible.



# FS2

## Flight Suit

The FS2 corporate flight suit consists of a comfortable elastic waist, button fly and belt loops. Baffled pockets with 2 way zips in the thighs and velcro closures on the lower leg pockets, make the FS2 trouser a professional garment that is operationally suited to customers who do not want knee pads or additional features of the GB Dynamic range.

The top is designed with Raglan sleeves that fall off the shoulders and large chest pockets. Velcro hook panels on both sleeves and chest for patches.

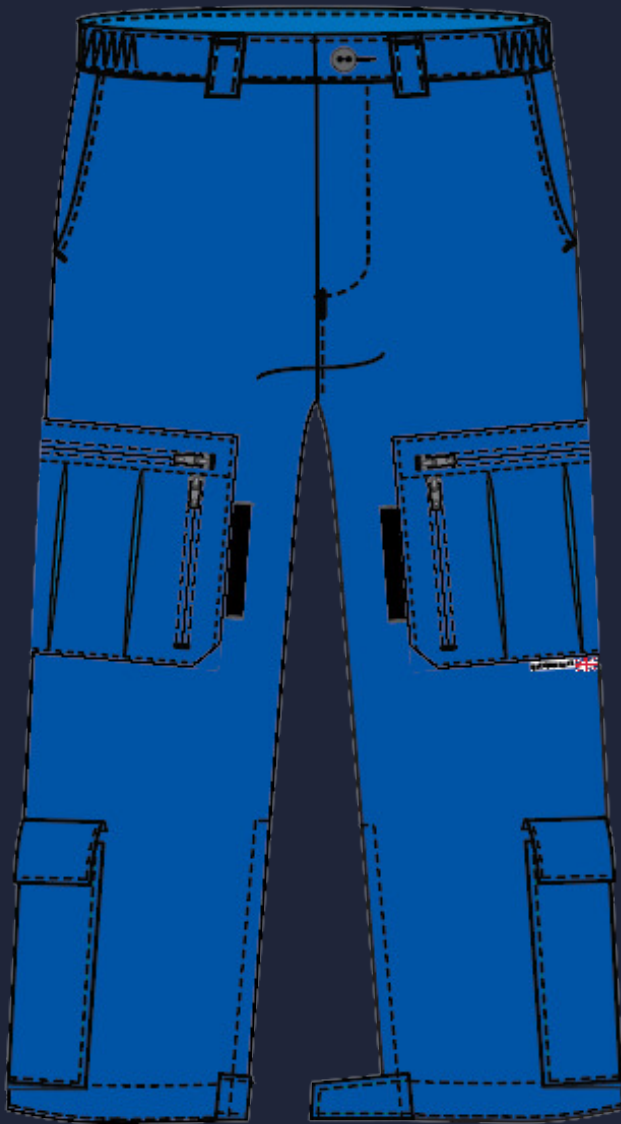

FS2 Trousers Front



FS2 Jacket Front

BADGE

C/O



FS2 Jacket Rear

# One Piece Flight Suit

A one piece flight crew coverall, lightweight and inherently fire retardant to EN 11612.



Options include:

- Smart reverse collar with Two way central zip.
- Shoulder epaulettes.
- Two Napoleon style zip down chest pockets for ease of access
- Metal D ring for attachment of equipment
- Upper arm mounted triple pen pocket
- Vented & pleated back for comfort
- Adjustable Velcro® closure cuffs
- Elasticated waist
- Twin hip pockets with access for base layers
- Generous cargo ankle pockets with Velcro® over flap.
- Velcro® flap ankle closure
- Whole of fleet custom options available



# LAYERING PRINCIPLES

Appropriate layering either retains heat or allows it to escape from the body. By allowing operators to layer up and down as environmental conditions dictate, companies maintain a professional appearance whilst staff can manage the heat and cold as it affects each individual.

The GB Dynamic Top is suited to hot humid weather, layering with a vest or even a thermal shirt provides comfort in cooler weather. The lined bomber jackets & fire resistant rain wear provides warmth in harsh winters and more extreme conditions.

Our range includes:

- T-Shirts
- Merino Thermals
- Hot weather Shirts
- Traditional Flight Jackete
- Traditional Trousers
- Dynamic Trousers
- Vest
- Bomber jacket
- Rain Wear

In addition to clothing, appropriate footwear allows crew to remain comfortable and focused on the task at hand. Warm, leather gortex lined boots for winter and lighter shoes for summer months provide thermal regulation across all seasons.



# Merino Thermals

Australian Made Merino Thermals in 230gsm to provide suitable layering approach to manage both the warm confines of the cabin and the colder temperatures on the ground. Unisex standard sizing in short sleeve crew neck and long sleeve crew or open zip neck.







# Vests

Ideally suited to flying operations where the cockpit can be warm with the doors closed and cold with the doors open.

Made from Rip-stop Nomex outer, with quilted inner lining to maintain body heat, with simple chest and hand pockets. A vest is a highly flexible uniform addition to managing environmental conditions.

Available in a range of colours and designs.

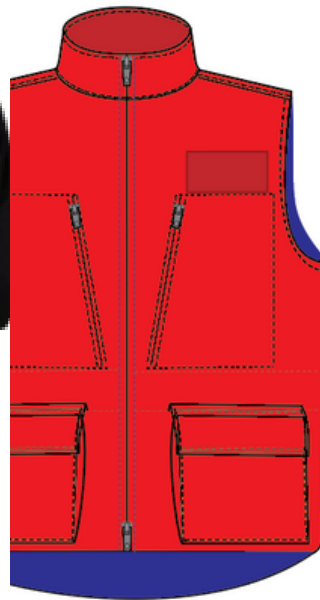

# Rain Wear with Zip in Zip out lining

Our range of rain wear is designed as a three in one solution, with a zip in zip out quilted lining to allow crews to manage heat and cold in addition to wet weather.

Highly suited across the range of environmental extremes, from Scotland or Norway in winter, to warmer climates in Australia with the lining removed in a summer rain storm.

Available in bespoke designs.



**PARAMEDIC** **MEDICAL  
TECHNICIAN**  
**ADVANCED  
PARAMEDIC**

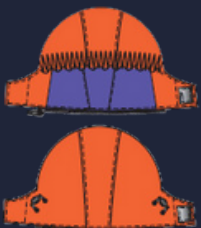



**POLICE**



# Public Order & Specialist Policing Roles

With a specific range of public order and policing garments available, we are more than capable of assisting operational needs. Rig Equipment have a specific line of kit meeting the stringent standards within these operations.

Reach out directly for more information.

Not available to general public.



# SCARPA

## Terra - GTX



Simple hiking style boot for those who prefer an immediately comfortable fit without compromising the quality of the product. Highly suited to emergency services and general aviation roles, In water-resistant full-grain leather with collar and gusset in Nubuck-coated leather with GORE-TEX Extended Comfort membrane for maximum breathability and waterproofing.

## Zen-Pro



Footwear for technical approach, via ferratas, and long walks. The materials have been carefully selected to guarantee performance, functionality and comfort. The upper is in water-resistant suede with Sock-Fit DVL construction system and the toe has a broad rubber protection. Extended Lacing down to the toe taken from the world of climbing, for maximum customisation and a comfortable fit. Spyder II sole with outsole in the Vibram® Mont compound.



# SCARPA TERRA

## UPPER

In water-resistant full-grain leather with collar and gusset in Nubuck-coated leather.

## LINING

GORE-TEX Extended Comfort membrane for maximum breathability and waterproofing.

## SOLE

Energy sole with Vibram® rubber outsole. Midsole in PU injected directly into the upper for maximum comfort and insert in TPU for improved stability.

## COLOURS & DESIGNS

Available in tan only & unisex design & sizes





# RUSH TRK GTX

## UPPER

Suede leather upper with higher ankle protection

## LINING

GORE-TEX Extended Comfort membrane.

## SOLE

The Presa® sole TRK-01

## COLOURS & DESIGNS

Available in multiple colour ranges & Mens & Womens specific designs & sizes









All Elements Protection combines the knowledge of the world leaders in search and rescue equipment and manufacturing, to bring best in breed technology to our customers

[allelementsprotection.com](http://allelementsprotection.com)